



### Features

- Industrial Data Acquisition
- KW Programming
- SCADA Configuration Design
- Data Cloud Upload
- Cloud Monitoring
- Industrial Scenario Simulation

### Product Overview

To effectively demonstrate typical industrial applications of IoT technology, Advantech leverages years of accumulated expertise and integrated product solutions to meticulously develop a remote device networking training solution. This solution covers the entire IoT technology chain from edge to cloud, providing a comprehensive experience integrating hardware and software. This training kit integrates Advantech's latest data modules and smart gateways with industrial software and cloud platforms. It covers subjects including industrial data acquisition, communication, KW Multiprog programming, SCADA configuration design, data cloud upload, and cloud visualization. It also incorporates concepts such as 4G/WiFi/Modbus/MQTT, edge computing, industrial gateways, cloud platforms, and digital twins. It is suitable for technical personnel training and enables rapid setup and demonstration of IoT technology scenarios.

### Solution Highlights

- Industry-Aligned: The solution architecture and training modules are designed based on typical IoT application scenarios, offering strong practicality and closely aligning with industry demands.
- Comprehensive and Advanced Functionality: The product features rich functionality and employs advanced technologies to meet diverse learning and practical needs.
- Extensive Expansion Interfaces: Equipped with communication and power expansion interfaces, it easily collects data from third-party devices like PLCs and smart meters or simulation equipment, supporting customized scenario training.
- Multi-Cloud Compatibility: Data cloud uploads support not only Advantech's Industrial Cloud Platform but also other mainstream cloud platforms, offering flexible choices for efficient and convenient operation.
- Portable and Compact Design: Compact and lightweight, ideal for carrying to training labs, academic exchanges, and solution demonstrations, enabling learning and practice anytime, anywhere.

# System Architecture

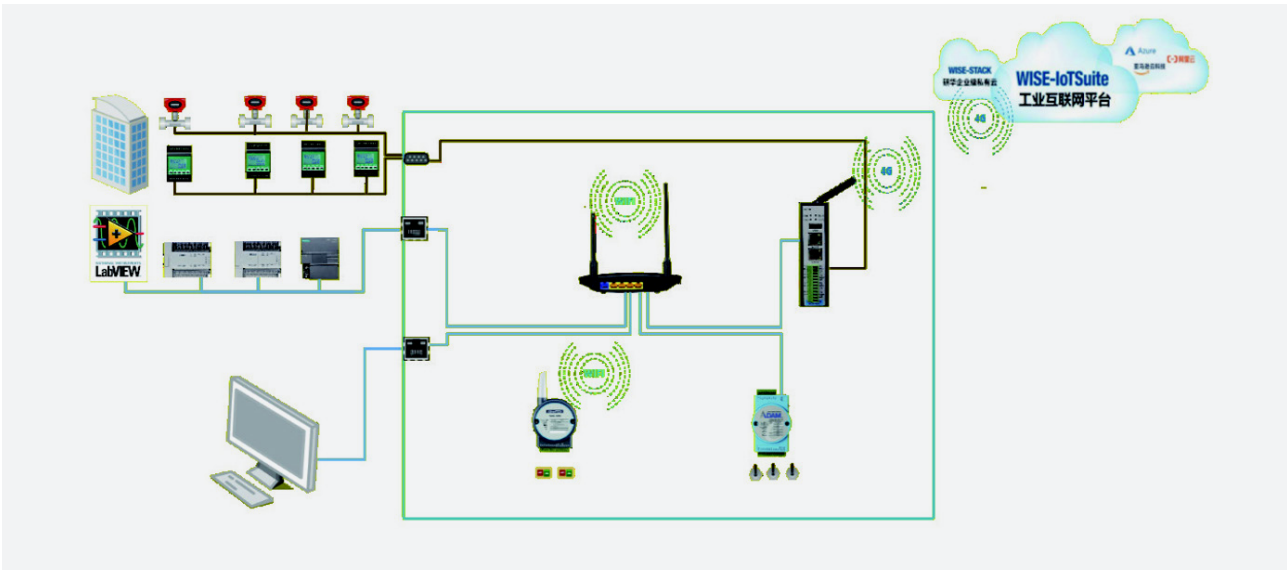

# Training Case Description

## Demobox Data Monitoring

Through Advantech modules/gateways, it collects the following signals in real-time and presents them via BI: PA1 Temperature, PA2 Humidity, PA3 Light Sensitivity, PA4 Vibration, PA5 Tilt, PA6 Smoke, PA7 Solar Power, PA8 is ADAM-6014's AI0, PA9 is ADAM-6014's AO0, PA10 is ADAM-6014's AO1, PD1 is DI0 of ADAM-6014, PD2 is DI1 of ADAM-6014, PD3 is DO0 of ADAM-6014, PD4 is DO1 of ADAM-6014.

## Smart Factory iFactory

Monitors and analyzes production line equipment parameters: temperature (PA1) and humidity (PA2). Simultaneously provides real-time video surveillance of production lines, tracks equipment output (PA6), analyzes equipment utilization rate (AI0), and displays fundamental equipment parameters including light sensitivity (PA3), vibration (PA4), tilt (PA5), smoke detection (PA6), and solar radiation (PA7). (Can be integrated with video surveillance cameras).



### Data Center Energy Monitoring System

Advantech tracks server room equipment temperature (PA2) and energy consumption (PA7). Displays instantaneous flow rate (PA5), ambient temperature (PA1), ambient humidity (PA2), UPS status, PUE (PA3) ratio of total energy consumed by the data center to IT load energy consumption, inverter operational status, temperature (PA1), and humidity (PA2). Monitors server room video feeds. Real-time variations in temperature (PA1), humidity (PA2), and irrigation water (AI0) are displayed, with detailed analysis of alarms for DO2, DI3, and DI1. (Can be integrated with video cameras).



### Wastewater Treatment Plant Monitoring System

This section can integrate weather data to monitor critical equipment metrics. Examples include: Yesterday's electricity consumption (PA3), Today's electricity consumption (AI1), Daily flow rate (PA1), Instantaneous flow rate (PA2), Total inflow volume (PA7), Total electricity consumption (PA6), Total chemical dosage (PA3), and Inflow/outflow indicators (AI0, PA2, PA1, PA4, etc.). Simultaneously display today's inspection (PA1) and work assignment (PA2) operational metrics, present reduction rate indicators (AO1, AO0, AI0), and analyze alarm information for DO3, DO2, DI2, and AI0.



### Electrical Cabinet Energy Monitoring

Displays basic equipment information. For example: DC operating voltage range DO1, rated output power DO3, maximum output power PA6, rated grid connection voltage AI0, permissible grid voltage range DO0, rated grid frequency DO2, power factor DI3, relative humidity PA2, efficiency DI2. Also displays the current status and output value DI2, PA1, PA2, AI1 for Power Cabinet 1 PA5, Power Cabinet 2 PA4, and Power Cabinet 3 PA3. Analyze the proportion of abnormal causes for machine parameters DO3, DI3, PA7, and PA5. Display real-time current data for power cabinets and detailed fault records for equipment PA1, PA2, and AI0.



### Agricultural IoT Platform

Monitor field parameters: temperature (PA1), humidity (PA2), light sensitivity (PA3), and evaporation rate (AI0). Display atmospheric conditions: temperature (PA2), light sensitivity (PA3), vibration (PA4), tilt (PA5), smoke (PA6), and solar radiation (PA7). Monitors atmospheric temperature (PA1) and humidity (PA2) trends for Plot A. Performs trend analysis on light sensitivity (PA3) and vibration (PA4). Monitors irrigation water (AI0) trends while also analyzing weekly meteorological trends (AI1), weekly rainfall and barometric pressure trends (PA5, PA7), and weekly light intensity (AO) trends.



## Hardware Module Functionality List

Product	Model	Description
ADAM-6024	DI	Flip the DI0 rocker switch module upward to set DI0 to 0. Flip the DI0 rocker switch module downward to set DI0 to 1. The same applies to the DI1 rocker switch
	DO	Set DO0 and DO1 to 1. The DO0 and DO1 LEDs on the panel light up. Otherwise, they turn off
	AI	Rotate the AI0 potentiometer to verify that the AI0 digital display matches the reading for channel ch-0 (range selection: +/-10V)
	AO	Enter the desired output voltage value or drag the slider. Verify that the values displayed on the panel's AO0/AO1 digital tubes match
WISE-4012	DI	Flip the DI2 rocker switch module upward to set DI0 to 1. Flip the DI0 rocker switch module downward to set DI0 to 0. The DI3 rocker switch operates similarly
	DO	Set DO0 and DO1 to 1 to illuminate the DO2 and DO3 LEDs on the panel; conversely, they will turn off
	AI	Rotate the AI1 potentiometer to verify that the AI1 digital display matches the channel-2 display
ECU-1051	COM1	Temperature Sensor 40001 Humidity Sensor 40002 Light Sensor 40003 Vibration Sensor 40004 Tilt Sensor 40005 Smoke Sensor 40006 Solar Panel 40007
	COM2	*Optional: Connect to electricity meter
	LAN1	Interface with ADAM-6024; Interface with WISE-4012
	LAN2	*Optional: Supports communication networking with Siemens SMART-200 PLC, Mitsubishi FX-5U PLC, and LabVIEW virtual devices

## Software IoT Edge Feature List

Product Features	Professional Edition	Enterprise Edition	Flagship Edition
Equipment Management	√	√	√
Data Acquisition	√	√	√
Data Forwarding	√	√	√
Visualization	√	√	√
OTA Updates	√	√	√
Log Service	√	√	√
Cloud-Edge Collaboration	√	√	√
Infrastructure Alerts	√	√	√
Gateway Management		√	√
Historical Data Storage		√	√
Basic Data Analysis		√	√
Advanced Data Analysis			√
Advanced Alert Center			√
Asset Modeling and Applications			√
Secondary Development Extensibility	Partially Supported	√	√

## Primary Product Components

Product	Model	Description
Data Acquisition Module	ADAM-6024	12-channel isolated universal TCP module supporting Modbus protocol for input/output
Smart Gateway	ECU-1051	Industrial IoT Cloud Intelligent Communication Gateway
Wireless Data Acquisition Module	WISE-4012	4-Channel Universal Input and 2-Channel Digital Output IoT Wireless I/O Module
Gateway Tool Software	EdgeLink Studio	Management tool for Advantech gateways and modules, enabling configuration and management of entire projects and all devices
Configuration Software	WebAccess/SCADA	Browser-based industrial IoT configuration software
Industrial Cloud Platform	WISE-IoTSuite	Full-Stack Industrial IoT Development Platform
Modbus RTU Smart Meter	WISE-E301	*Optional, Smart Meter

**The Demobox integrates extensive software and hardware resources. For detailed functionality, refer to the specific user manual, including but not limited to:**

- Power & Interfaces: Power socket, pass-through Ethernet port, terminal blocks
- Indicators and Display: LED indicators, digital display tubes
- Control Components: Rocker switch, Variable potentiometer
- Sensors: Light sensor, tilt sensor, temperature/humidity sensor, smoke detector, solar panel, vibration sensor
- PLC Development Software and Hardware: KW Multiprog PLC Development Software (Third-Party), Mitsubishi FX-5UPLX PLC, Siemens Smart-200 PLC
- Virtual Instruments: LabVIEW (Third-Party)

## Primary Product Components

Product	Model	Description
Remote Device Networking Training Kit	Basic Package	Rapidly establish communication and data collection solutions for field scenarios and equipment operation information systems
IoT Edge Device Networking and Edge Computing Services	Enterprise Edition	Deployable at the edge to collect device data locally, manage devices, and perform data analysis, processing, forwarding, and visualization
Dashboard BI Software	Professional Edition	Standalone deployment supporting integration with any compatible data source
SaaS Composer 3D Visualization Service	Pro Edition	Standalone deployment, supports integration with any compatible data source
TPM Comprehensive Production Maintenance Solution	Platform Edition	Industrial Internet Platform, including IoT Edge Flagship Edition with 10,000 physical points, DataInsight 500 datasets, etc.WISE-IoTSuite Suite
Technical Support	Basic Package	Remote technical support, technical development support, on-site technical support