

ULI-234TCL BB-4850P

Optically Isolated RS-422/485 Repeater/Extender



Features

- 1.2 km signal extension
- 2 kV optical isolation for device and data lines
- Add up to 32 nodes to RS-485 network
- Inline installation
- Modbus support
- External 12 Vdc power source required (included)

Introduction

Model ULI-234TCL is an RS-422/485 signal repeater with 2 kV optical isolation on data lines and terminal blocks for RS-422, RS-485 2 or 4-wire modes. It extends RS-422/485 an additional 1.2 km to double the communication range. Another benefit is the ability to add another 32 nodes to an RS-485 network and join 2 and 4 wire systems. Its compact design fits almost anywhere. Wiring schematic on the label eliminates guesswork. 12 Vdc PSU is required and included with USA, EU, UK, AU, UP and CN blades.

Specifications

Serial Technology

- Connector Terminal block
- Signals TDA(-), TDB(+), RDA(-), RDB(+), GND
- Modes RS-485 2-wire or 4-wire, RS-422 4-wire
- LED Indicators Data flow and Power

Isolation

- Method Optical
- Rating 2000 V
- Lines Protected Data lines

Surge Suppression

- Method TVS
- Rating 6.5 V, bi-directional, 600W peak power dissipation
- Lines Protected Data lines

Industrial Bus

- Protocol Modbus ASCII / RTU

Terminal Block

- Wire Size 22 to 14 AWG
- Torque 0.5 Nm

Power

- Connector Terminal block
- Voltage 10 ~ 14 Vdc
- Consumption 1.0 W
- Source External 12 Vdc source, required.
Note: one wall transformer power supply included.

Power Supply, included

- Input Voltage 96 ~ 264 Vac
- Input Connections AC blades for USA, EU, UK, AU, CN, JP
- Output Connections Stripped and tinned leads
- Output Current 500 mA
- Output Power 6 W
- Output Voltage 12 Vdc
- Efficiency Level VI

Mechanical

- Enclosure Material Plastic
- IP Rating 30
- Dimensions 97 x 61 x 25 mm
- Mounting In-line installation

Environmental

- Operating Temperature 0 to +40 °C
- Operating Humidity 0 to 95%, non-condensing

Meantime Between Failures (MTBF)

- MTBF, hours 453103
- Calculation Method MIL217F Parts Count Reliability Prediction

Regulatory Certifications

- Approvals FCC
- CE Directives 2014/30/EU – Electromagnetic Compatibility Directive
2011/65/EU – Amended by (EU) 2015/863 Reduction of Hazardous Substances Directive (RoHS)
2012/19/EU – Waste Electrical and Electronic Equipment
EN 55032 (Class B) – Electromagnetic Compatibility of Multimedia Equipment – Emission Requirements
EN 55024 – Information Technology Equipment – Immunity Characteristics – Limits and Methods of Measurement
EN 60950-1 +A1 +A11 +A12 +A2 – Information Technology Equipment – Safety – Part 1 General Requirements

CE Standards

Ordering Information

Model	Part Number to Order	Description
ULI-234TCL	BB-4850P	Industrial Isolated RS-422/485 Repeater

ULI-234TC
ULI-234TCH
ULI-234TCI
ULI-234TE

BB-4850PDR
BB-4850PDR-HS
BB-4850PDRI
BB-4850PDRI-PH

**Industrial-grade, Isolated
RS-422/485 Repeaters**



ULI-234TC
BB-4850PDR

ULI-234TCI
BB-4850PDRI



Features

- Extend RS-422/RS-485 signals an extra 1.2 km
- Add up to 32 more nodes to RS-485 network
- 2 kV optical isolation protection
- 600 W transient voltage suppression
- Industrial-grade design, specifications and certifications
- Industrial protocol support
- Wide operating temperature options
- DIN rail, panel mount or in-line installation
- External PSU required

Introduction

These rugged isolated repeaters from Advantech are ideal for demanding industrial applications. Heavy-duty repeaters can be DIN rail mounted in a cabinet or directly to a panel. Advanced EMC specifications support 2 kV isolation on input and output lines. Models ULI-234TCI and ULI-234TE protect input and output lines plus the power line providing triple protection against electrical transients. Model ULI-234TE is a premium performance repeater for electrical substation and other advanced applications.

Specifications

Serial Technology

• **Data Rate, Biasing, Termination**

Model:	Data Rate (max):	Biasing:	Termination:
ULI-234TC	115.2 kbps	-	-
ULI-234TCH	1.5 Mbps	-	-
ULI-234TCI	115.2 kbps	Built-in, switchable, 1.2KΩ, TX/RX	Built-in, switchable, 120Ω
ULI-234TE			

- **LED Indicators** Data flow, Power
- **RS-422/485 Connector** Terminal block
- **RS-422/485 Signals** TDA(-), TDB(+), RDA(-), RDB(+), GND
- **RS-422/485 Modes** RS-485 2-wire or 4-wire, RS-422 4-wire
- **Industrial Bus**

Model:	Industrial Protocol:
ULI-234TC	Modbus ASCII / RTU
ULI-234TCH	
ULI-234TCI	Allen-Bradley® 1747-AIC 485 (DH-485), Modbus ASCII / RTU
ULI-234TE	Modbus ASCII / RTU

Isolation & Surge Suppression

Model:	Optical Isolation:	Isolated Lines:	Surge Suppression:	Surge Rating:
ULI-234TC	2 kV	Input, output	500 W, TVS	6.5V bi-directional avalanche breakdown device, 500W peak power dissipation, <1 psec, response time
ULI-234TCH				
ULI-234TCI		Input, output, power	600 W, TVS	12V bi-directional avalanche breakdown device. 600 W peak power dissipation, < 1 psec responses time
ULI-234TE				

Power

Model:	Connector:	Input:	Source:	Consumption:
ULI-234TC	Terminal block	10 to 30 Vdc	External, not included	0.7 W
ULI-234TCH				1.9 W
ULI-234TCI		10 to 48 Vdc		0.5 W
ULI-234TE				0.5 W

Mechanical

Model:	Enclosure:	Dimensions, mm:	Mounting:	Weight, gm
ULI-234TC	IP20 plastic	25 x 79 x 106	DIN rail, panel mount option	90.72
ULI-234TCH		25 x 79 x 95		
ULI-234TCI	IP30 metal	115.1 x 89.6 x 32.1	DIN rail	222.0
ULI-234TE		132 x 93 x 31	Panel mount	208.65

Meantime Between Failures (MTBF)

- **Calculation Method** MIL217F Parts Count Reliability Prediction

Model:	Hours:
ULI-234TC	225299
ULI-234TCH	117376
ULI-234TCI	114696
ULI-234TE	122832

Environmental

Model:	Operating Temperature:	Storage Temperature:	Operating Humidity:
ULI-234TC	-40 to +80 °C	-40 to +85 °C	0 to 95%, non-condensing
ULI-234TCH			
ULI-234TCI			
ULI-234TE			

Dimensions - ULI-234TC

Unit = mm

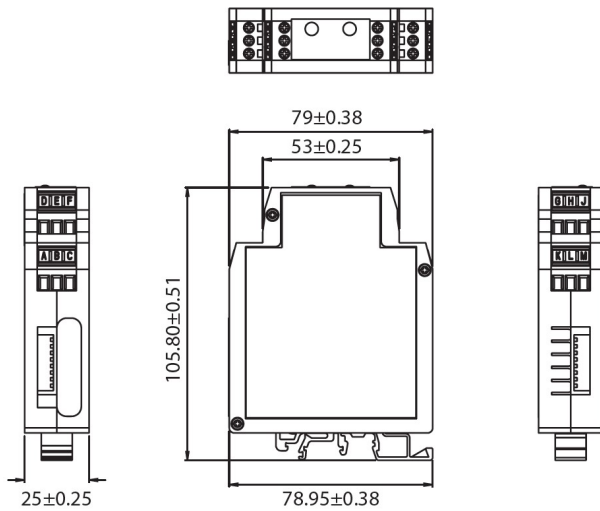

Dimensions - ULI-234TCH

Unit = mm / in

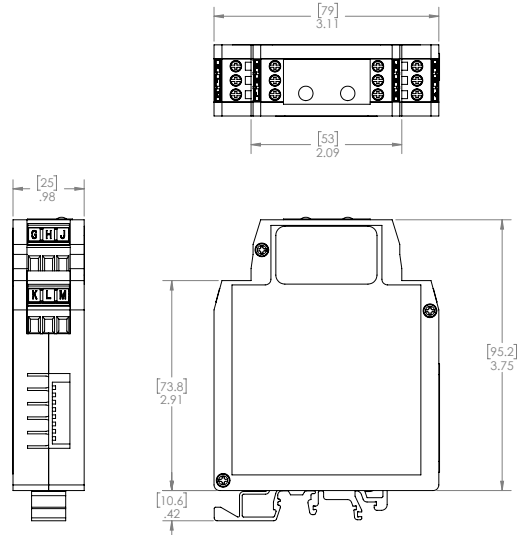

Dimensions - ULI-234TCI

Unit = mm / in

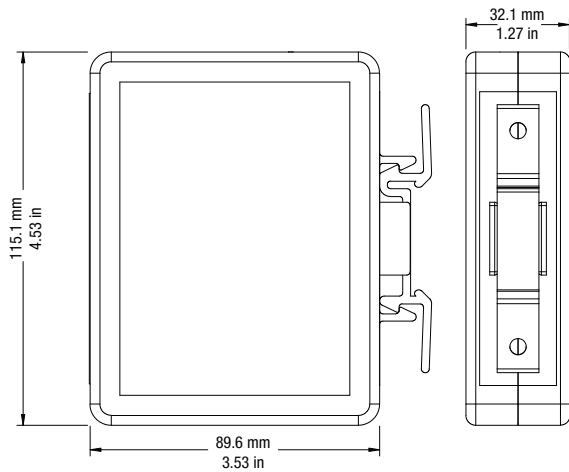

Dimensions - ULI-234TE

Unit = in / mm

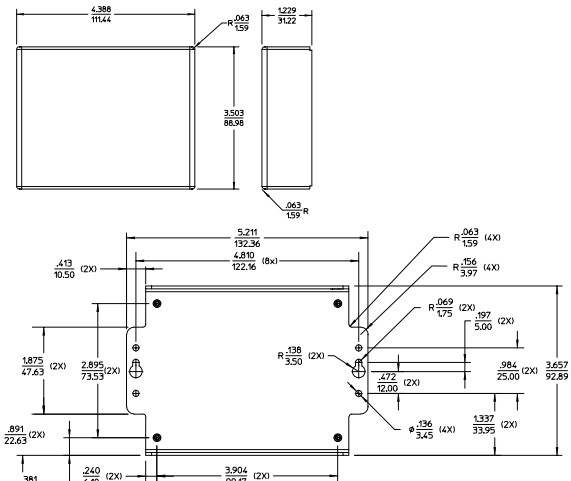

Ordering Information

Model	Part Number to Order	Description
ULI-234TC	BB-4850PDR	Industrial Isolated RS-422/485 Repeater – 2 kV 2-way Isolated, 115.2 kbps, wide operating temperature range. <i>PSU not included.</i>
ULI-234TCH	BB-4850PDR-HS	Industrial Isolated RS-422/485 Repeater – 2 kV 2-way Isolated, 1.5 Mbps, wide operating temperature range. <i>PSU not included.</i>
ULI-234TCI	BB-4850PDRI	Industrial Isolated RS-422/485 Repeater – 2 kV 3-way Isolated, 115.2 kbps, wide operating temperature range. <i>PSU not included.</i>
ULI-234TE	BB-4850PDRI-PH	Industrial Isolated RS-422/485 Repeater – 2 kV 3-way Isolated, 115.2 kbps, wide operating temperature range. <i>PSU not included.</i>

ULI-234 Series Selection Guide

Industrial Heavy-duty, Isolated RS-422/485 Repeaters



Common Features

- Extend RS-422/RS-485 signals an extra 1.2 km
- Add up to 32 more nodes to RS-485 network
- 2 kV optical isolation protection
- 600 W transient voltage suppression
- Industrial-grade design, specifications and certifications
- Industrial protocol support
- Wide operating temperature options
- External powering (PSU required, sold separately)
- DIN rail, panel mount or in-line installation

Serial Converters Comparison Table

Model Number	ULI-234TCL	ULI-234TC	ULI-234TCH	ULI-234TCI	ULI-234TE
Part Number to Order	BB-485OP	BB-485OPDR	BB-485OPDR-HS	BB-485OPDRI	BB-485OPDRI-PH
Description	2-way Isolated RS-422/485 Repeaters			3-way Isolated RS-422/485 Repeater – A-B® 1747-AIC DH-485	Hardened, 3-way Isolated RS-422/485 Repeater – shock, drop, vibration tested
Key Features	Two terminal blocks join 2-wire and 4-wire systems	UL Recognized Component	1.5 Mbps, high-speed	UL C1/D2, UL 508, 3-way Isolation, Oil & Gas applications	UL C1/D2, IEC61850-3, IEEE-1613, 3-way Isolation, Electrical substations
Industrial Rating	Heavy-duty				
Isolation	2 kV, input/output			2 kV, input/output/power	
Surge Protection	600 W, TVS	500 W, TVS	600 W, TVS		
Industrial Bus	Modbus ASCII / RTU			Allen-Bradley® 1747-AIC 485 (DH-485), Modbus ASCII / RTU	Modbus ASCII / RTU
Baud Rate, max.	115.2 kbps		1.5 Mbps	115.2 kbps	
RS-422/485 Connector	Terminal block				
Automatic Send Data Control	✓	✓	✓	–	
Power Input	10 to 14 Vdc	10 to 30 Vdc		10 to 48 Vdc	
Power Source	External PSU				
Power Connector	Terminal block				
Operating Temperature	0 to +40 °C	-40 to +80 °C			-40 to +85 °C
Enclosure	IP30 plastic	IP20 plastic			IP30 metal
Dimensions	97 x 61 x 25 mm	25 x 79 x 106 mm	25 x 79 x 95 mm	115.1 x 89.6 x 32.1 mm	132 x 93 x 33 mm
Mounting Installation	In-line	DIN rail	DIN rail, panel mount option	DIN rail	Panel mount
MTBF (MIL217F), hours	453103	225299	117376	114696	122832
Regulatory/Approvals/ Certifications	FCC, CE, RoHS, WEEE				
	EN55032, EN55024, EN-60950-1+A1+A12+A2	EMC: EN 55011: 2016+A2: 2021 Class A Group 1 BS EN 55011: 2016+A2: 2021 Class A Group 1 CISPR 11: 2015+AMD1: 2016+AMD2: 2019 Ed 6.2 Class A Group 1 EN 55032: 2015+A1: 2020 Class A / BS EN 55032: 2015+A1: 2020 Class A CISPR 32: 2015+AMD1: 2019 Class A EN IEC 61000-6-4: 2019 / BS EN IEC 61000-6-4: 2019 EN 55035: 2017+A11: 2020 / BS EN 55035: 2017+A11: 2020 EN IEC 61000-6-2: 2019 / BS EN IEC 61000-6-2: 2019 EN 61000-4-2: 2009 / EN IEC 61000-4-3: 2020 / EN 61000-4-8: 2010	EMC: EN 55011: 2016+A2: 2021 Class A Group 1 BS EN 55011: 2016+A2: 2021 Class A Group 1 CISPR 11: 2015+AMD1: 2016+AMD2: 2019 Ed 6.2 Class A Group 1 EN 55032: 2015+A1: 2020 Class A / BS EN 55032: 2015+A1: 2020 Class A CISPR 32: 2015+AMD1: 2019 Class A EN IEC 61000-6-4: 2019 / BS EN IEC 61000-6-4: 2019 EN 55035: 2017+A11: 2020 / BS EN 55035: 2017+A11: 2020 EN IEC 61000-6-2: 2019 / BS EN IEC 61000-6-2: 2019 EN 61000-4-2: 2009 / EN IEC 61000-4-3: 2020 / EN 61000-4-8: 2010	EN55032/B, EN55024, EN61000-6-1	EMC: EN 55011: 2016+A2: 2021 Class A Group 1 BS EN 55011: 2016+A2: 2021 Class A Group 1 CISPR 11: 2015+AMD1: 2016+AMD2: 2019 Ed 6.2 Class A Group 1 EN 55032: 2015+A1: 2020 Class A CISPR 32: 2015+AMD1: 2019 Class A EN IEC 61000-6-4: 2019 / BS EN IEC 61000-6-4: 2019 EN 55035: 2017+A11: 2020 / BS EN 55035: 2017+A11: 2020 EN IEC 61000-6-2: 2019 / BS EN IEC 61000-6-2: 2019 EN 61000-4-2: 2009 / EN IEC 61000-4-3: 2020 / EN 61000-4-8: 2010
	UL Recognized Component #E327848	UL Recognized Component #E327848, KCC	-	UL C1/D2 #EE337172*, UL 508 #E327848	UL C1/D2 #EE337172*, IEC61850-3†, IEEE-1613‡



*UL C1/D2 #E337172

†IEC61850-3

‡IEEE-1613